

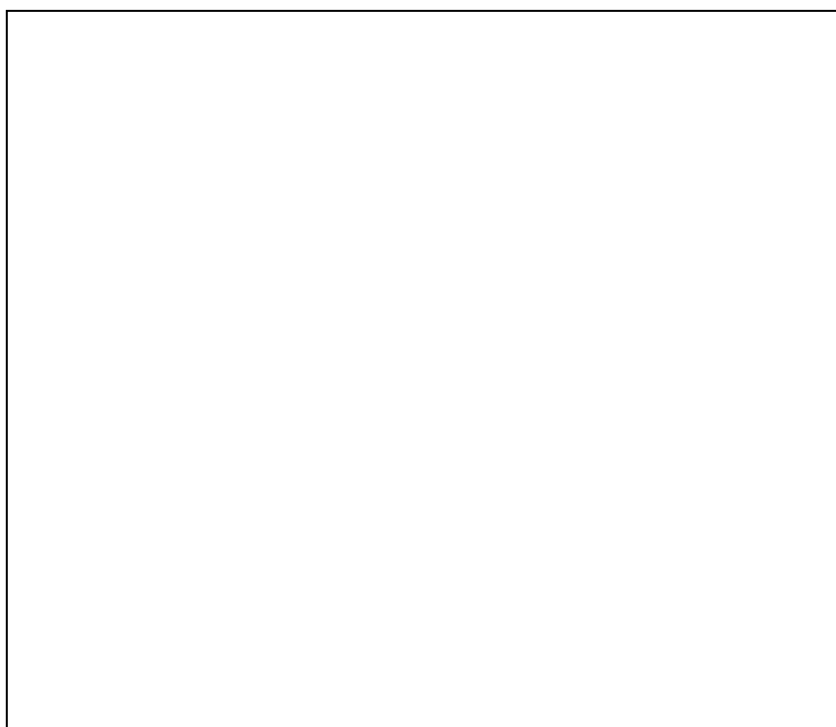

CPS 2



IT	6
GB	8
FR	10
DE	12
NL	14
DK	16
ES	18
PT	20
FI	22
SE	24

- IT AVVERTENZE:** Prima di utilizzare il compressore, leggere attentamente le istruzioni riportate nel seguente manuale
- GB WARNING:** Please read understand this manual before opertaing the compressor
- FR AVERTISSEMENT:** Veuillez lire attentivement toutes les instrcions avant de mettre à la sécurité
- DE HINWEIS:** Vor der Benutzung des Kompressors die im vorliegenden Handbuch enthaltenen Anweisungen aufmerksam lesen
- NL WAARSCHUWING:** Lees voor het gebruik van de compressor de aanwijzingen in deze handleiding zorgvuldig door
- DK ADVARSEL:** Før kompressoren tages i brug, skal instruktionerne i denne vejledning læses grundigt
- ES ADVERTENCIAS:** Antes de utilizar el compresor, lea atentamente las instrucciones descritas en el presente manual
- PT AVIOS:** Ante de utilizar o compressor, ler bem as instruções contidas no seguinte manual
- FI VAROITUKSET:** Lue tarkkan tässä käsikirjassa anneut ohjeet ennen kompressorin käyttöä
- SE VARNING:** Läs manuales instruktioner noga innan du använder kompressorn



- IT LEGGERE IL LIBRETTO DI ISTRUZIONI**
Prima di posizionare, mettere in funzione o intervenire sul compressore, leggere attentamente il libretto istruzioni.
- GB READ THE INSTRUCTION HANDBOOK**
Before positioning, operating or adjusting the compressor, read the instruction handbook carefully.
- FR LIRE LA NOTICE D'INSTRUCTIONS**
Avant de positionner, mettre en service ou intervenir sur le compresseur, lire attentivement la notice d'instructions.
- DE GEBRAUCHSANLEITUNG LESEN**
Lesen Sie die Gebrauchsanleitung sorgfältig durch, bevor Sie den Kompressor aufstellen, in Betrieb nehmen oder Eingriffe daran vornehmen.
- NL LEES HET INSTRUCTIEBOEKJE**
Lees het instructieboekje aandachtig alvorens de compressor te plaatsen, inwerking te stellen of er werkzaamheden aan te verrichten
- DK LÆS BRUGERVEJLEDNINGEN**
Læs brugervejledningen grundigt før kompressoren tages i brug, eller der udføres indgreb på den.
- ES LEER EL MANUAL DE INSTRUCCIONES**
Antes de colocar, poner en función o intervenir en el compresor, leer atentamente el manual de instrucciones.
- PT LER O MANUAL DE INSTRUÇÕES**
Antes de colocar, pôr a funcionar ou intervir no compressor, ler atentamente este manual de instruções.
- FI LUE OHJEKIRJA**
Lue ohjekirja huoleellisesti ennen laitteen paikoilleen asettamista, käynnistämistä tai toimenpiteiden suorittamista.
- SE LÄS MANUALEN**
Läs manualen noga innan du installerar, använder eller utför underhållsarbete på kompressorn.



- IT RISCHIO DI SCOSSA ELETTRICA**
Attenzione: prima di effettuare ogni intervento sul compressore è obbligatorio disattivare l'alimentazione elettrica sulla macchina stessa.
- GB RISK OF ELECTRIC SHOCK**
Caution: before doing any work on the compressor it must be disconnected from the power supply.
- FR RISQUE D'ELECTROCUTION**
Attention : avant d'effectuer toute intervention sur le compresseur, il est obligatoire de désactiver l'alimentation électrique de la machine.
- DE GEFÄHRLICHE ELEKTRISCHE SPANNUNG**
Vorsicht! Schalten Sie vor jedem Eingriff am Kompressor die Stromzufuhr aus.
- NL GEVAAR VOOR EEN ELEKTRISCHE SCHOK**
Let op: schakel de stroomtoevoer op de machine beslist uit alvorens werkzaamheden op de compressor uit te voeren.
- DK FARE FOR ELEKTRISK STØD**
Advarsel: det er påbudt at afbryde strømforsyningen til kompressoren, før der udføres nogen form for indgreb på den.
- ES RIESGO DE CHOQUE ELÉCTRICO**
Atención: antes de efectuar cualquier tipo de intervención en el compresor, es obligatorio desconectar la alimentación eléctrica de la máquina.
- PT PERIGO DE CHOQUE ELÉCTRICO**
Atenção: antes de efectuar qualquer intervenção no compressor é obrigatório desligar a alimentação eléctrica da máquina.
- FI SÄHKÖISKUN VAARA**
Huomio: kompressorista on katkaistava virta ennen toimenpiteiden suorittamista laitteeseen.
- SE RISK FÖR ELEKTRISK STÖT**
Varning! Innan du utför underhållsarbete på kompressorn, måste du koppla från strömtillförseln till maskinen.



- IT RISCHIO DI TEMPERATURE ELEVATE**
Attenzione: nel compressore ci sono alcune parti che potrebbero raggiungere temperature elevate.
- GB RISK OF HIGH TEMPERATURES**
Caution: the compressor contains some parts which might reach high temperatures.
- FR RISQUE DE TEMPERATURES ELEVEES**
Attention : certaines parties du compresseur peuvent atteindre des températures élevées.
- DE GEFÄHRDUNG DURCH HEISSE OBERFLÄCHEN**
Vorsicht! Im Kompressor befinden sich einige Teile, die sich stark erhitzen können.
- NL GEVAAR VOOR HOGE TEMPERATUREN**
Let op: in de compressor kunnen enkele onderdelen hoge temperaturen bereiken.
- DK RISIKO FOR HØJE TEMPERATURER**
Advarsel: der er dele i kompressoren, der kan opnå meget høje temperaturer.
- ES RIESGO DE TEMPERATURAS ELEVADAS**
Atención: algunas partes del compresor pueden alcanzar temperaturas elevadas.
- PT PERIGO DE TEMPERATURAS ELEVADAS**
Atenção: no compressor há algumas partes que poderão alcançar temperaturas elevadas.
- FI KORKEIDEN LÄMPÖILOJEN VAARA**
Huomio: jotkin kompressorin osat saattavat saavuttaa hyvin korkeat lämpötilat.
- SE RISK FÖR HÖG TEMPERATUR**
Varning! Inuti kompressorn finns det vissa delar som kan uppnå mycket hög temperatur.



- IT RISCHIO DI PARTENZA ACCIDENTALE**
Attenzione: il compressore potrebbe ripartire in caso di black-out e successivo ripristino di tensione.
- GB RISK OF ACCIDENTAL START-UP**
Attention, the compressor could start automatically after a power-cut if not switched off.
- FR RISQUE DE DEMARRAGE ACCIDENTEL**
Attention : après une coupure de courant, au retour de l'alimentation, le compresseur risque de redémarrer.
- DE GEFÄHRDUNG DURCH PLÖTZLICHEN START**
Vorsicht! Der Kompressor kann nach einen Stromausfall plötzlich neustarten.
- NL GEVAAR VOOR ONVOORZIEN OPSTARTEN**
Let op: de compressor kan bij stroomuitval en daarop volgend herstel van de voedingsspanning opnieuw starten.
- DK RISIKO FOR UTILSIGTET IGANGSÆTNING**
Advarsel: kompressoren kan starte igen i tilfælde af black-out ved efterfølgende genetablering af strømforsyningen.
- ES RIESGO DE ARRANQUE ACCIDENTAL**
Atención: el compresor puede volver a arrancar tras un corte de energía eléctrica y sucesivo restablecimiento de tensión.
- PT PERIGO DE ARRANQUE ACIDENTAL**
Atenção: o compressor poderá começar a funcionar após uma falta de corrente quando essa voltar.
- FI VAHINGOSSA KÄYNNISTYMISEN VAARA**
Huomio: kompressorin saattaa käynnistyä vahingossa sähkökatkon tapahtuessa ja sitä seuraavan virran uudelleenkytkemisen seurauksena.
- SE RISK FÖR OFRIVILLIG START**
Varning! Kompressorn kan återstarta automatiskt då strömmen återställs efter ett strömavbrott.

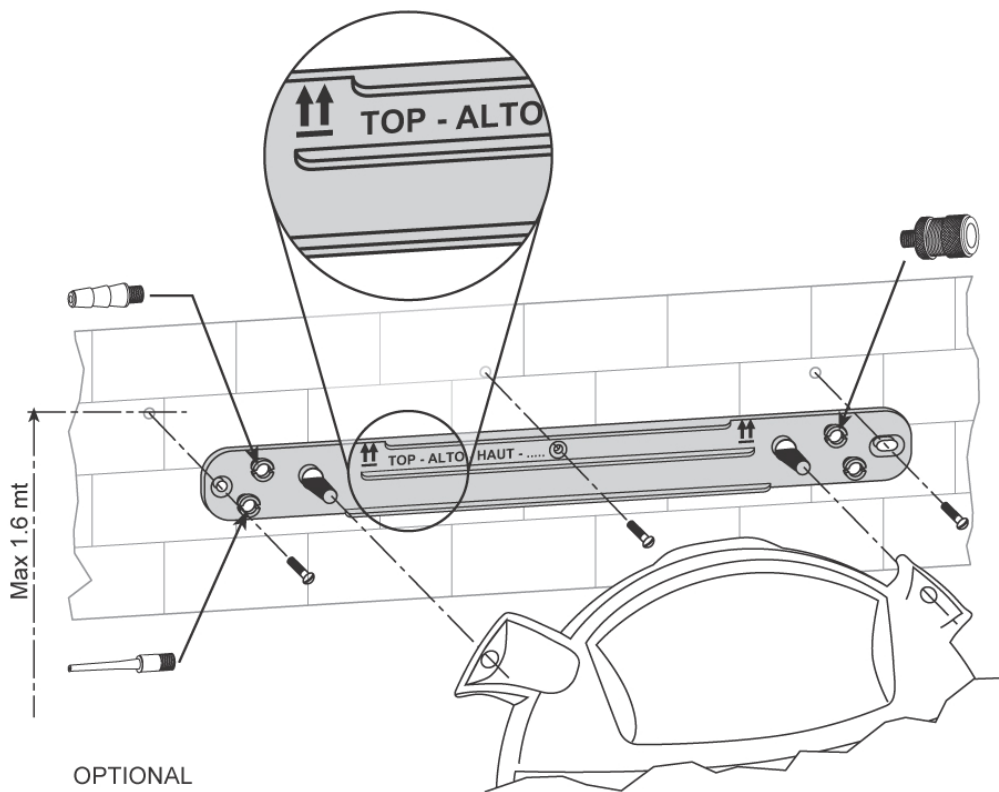
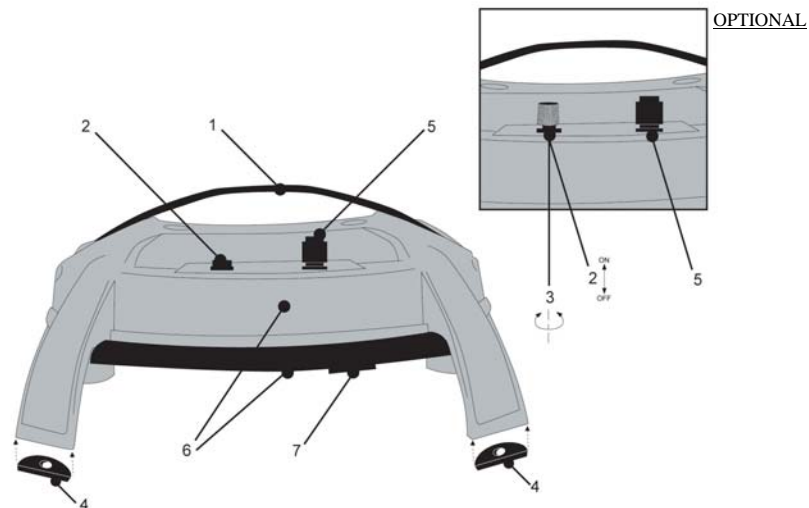

1. MANIGLIA / HANDLE / POIGNEE / GRIFF / HANDGRIEP / HÄNDTAG / EMPUÑADURA / PEGA / KAHVA / HANDTAG

2. INTERRUPTORE ON-OFF / ON-OFF SWITCH / INTERRUPTEUR ON-OFF / EIN-/AUSSCHALTER / AAN/UIT SCHAKELAAR / ON-OFF KONTAKT / INTERRUPTOR ON-OFF / INTERRUPTOR ON-OFF / ON-OFF –KATKAISIN / STRÖMBRYTARE

3. RIDUTTORE DI PRESSIONE / PRESSURE REDUCER / REDUCTEUR DE PRESSION / DRUCKREDUZIERER / REDUCEERVENTIEL / REDUKTIONSVENTIL / . REDUCTOR DE PRESIÓN / REDUTOR DE PRESSÃO / . PAINEENALENNUSVENTTIILI / TRYCKREGULATOR

4. GOMMINI / RUBBER FEET / CAPSULES EN CAOUTCHOUC / GOMMIFÜSSE / RUBBER VOETJES / GUMMIRINGE / TACOS DE GOMA / BORRACHAS / KUMIPALAT / GUMMIFÖTTER

5. USCITA ARIA COMPRESA / COMPRESSED AIR OUTLET / SORTIE D'AIR COMPRIÈME / DRUCKLUFTAUSGANG / UITGANG PERSLUCHT / UDGANG FOR TRYKLUFFT / SALIDA AIRE COMPRIMIDO / SAÍDA DO AR COMPRIMIDO / PAINEILMAN ULOSTULO / TRYCKLUFTSUTGÅNG

6. CARENATURA DI PROTEZIONE/ HOUSING / CARTER DE PROTECTION / SCHUTZGEHÄUSE / BESCHERMKAP / BEKYTTELSBEKLÆDNING / REVESTIMIENTO DE PROTECCIÓN / CARÇA DE PROTECÇÃO / SUOJAVAIPPA / SKYDDSBEKLÄDNAD

7. TARGHETTA DATI / DATA PLATE / PLAQUETTE SIGNALETIQUE / DATENSCHILD / TYPEPLAATJE / DATAPLAD / PLACA DE DATO / PLACA DE IDENTIFICAÇÃO / TIETOKILPI8. CONDENSATE DRAIN / MÄRKPLÄT / BILGI ETIKETI

SAVE THESE INSTRUCTIONS AND MAKE THEM AVAILABLE TO OTHER USERS OF THIS TOOL!

IMPORTANT INFORMATION

Read and understand all the operating instructions, safety precautions and warnings in the user guide before operating or maintaining this compressor. Most accidents that result from compressor operation and maintenance are caused by the failure to observe basic safety rules or precautions. An accident can often be avoided by recognizing a potentially hazardous situation before it occurs, and by observing appropriate safety procedures. Only use the compressor as recommended by the manufacturer.

SAFETY

(IMPORTANT SAFETY INSTRUCTIONS FOR THE USE OF THE COMPRESSOR)

1. NEVER TOUCH MOVING PARTS
2. NEVER OPERATE WITHOUT ALL GUARDS IN PLACE
3. ALWAYS WEAR EYE PROTECTION compressed air must never be aimed at anyone or any part of the body.
4. PROTECT YOURSELF AGAINST ELECTRIC SHOCK; prevent body contact with grounded surfaces such as pipes, radiators, ranges and refrigeration enclosures. Never operate the compressor in damp or wet locations.
5. DISCONNECT THE COMPRESSOR from the electric mains before operating, inspecting, servicing and cleaning the unit and before replacing or checking any parts. 6. ACCIDENTAL STARTING; do not move the compressor while it is still plugged into the mains. Make sure that the main switch is turned OFF before plugging the compressor into the mains. 7. STORE COMPRESSOR PROPERLY when not in use, the compressor should be stored in a dry place.
8. KEEP WORK AREA CLEAN; cluttered areas invite injuries. Clear all work areas of unnecessary tools, debris, furniture etc. Risk of electric shock – do not expose the compressor to rain and don't use it in damp or wet locations. Keep work area well lit and well ventilated. Risk of fire or explosion. Do not carry and operate the compressor or any other electrical device near the spray area. Don't use the compressor in the presence of flammable liquids or gases. Compressor produces sparks during operation. Never use compressor in sites containing lacquer, paint, benzene, thinner, gasoline, gases, adhesive agents and other materials which are combustible or explosive.
9. KEEP CHILDREN AWAY; do not let other people come into contact with compressor extension cable. All visitors should be kept safely away from work area.
10. DRESS PROPERLY; do not wear loose clothing or jewelry. They can be caught in moving parts. Wear protective hair covering to contain long hair.
11. DO NOT MISHANDLE CABLE; never pull it to disconnect from the plug socket. Keep cable from heat, oil and sharp edges and avoid crushing it.
12. MAINTAIN COMPRESSOR WITH CARE inspect cable periodically and if damaged, have it repaired by an authorised service facility inspect extension cords periodically and replace if damaged.
13. OUTDOOR USE EXTENSION CABLE; when compressor is used outdoors, use only extension cable intended for use outdoors and so marked.
14. STAY ALERT; watch what you are doing. Use common sense. Do not operate compressor when you are tired it should never be used by you if you are under the influence of alcohol, drugs or medication that make you drowsy.
15. CHECK DAMAGED PARTS AND AIR LEAKS; before further use of the compressor, a guard or other part which is damaged should be carefully checked to determine that the compressor will operate properly and perform its intended function. Check for alignment of moving parts, binding of moving parts, breakage of parts, mounting, air leaks and any other conditions that may affect its operation. A guard or other part that is damaged should be properly repaired or replaced by an authorised service centre unless otherwise indicated elsewhere in the user guide. Have defective pressure switches replaced by an authorised service centre. DO NOT USE THE COMPRESSOR IF THE PRESSURE SWITCH IS FAULTY.
16. USE THE COMPRESSOR CORRECTLY OPERATE THE COMPRESSOR ACCORDING TO THE INSTRUCTIONS PROVIDED HEREIN; never allow the compressor to be operated by children, individuals unfamiliar with its operation or unauthorised personnel. The compressor has been designed and manufactured exclusively to produce compressed air. EVERY OTHER USE, DIFFERENT AND NOT FORESEEN BY ALL INDICATED, RELIEVES THE MANUFACTURER OF POSSIBLE CONSEQUENT RISKS. In any event the use of the compressor different to that agreed in the purchase order RELIEVES THE MANUFACTURER FROM ALL LIABILITIES WITH REGARD TO POSSIBLE MATERIAL DAMAGE AND PERSONAL INJURY.
17. KEEP MOTOR AIR VENT CLEAN.

18. OPERATE COMPRESSOR AT THE RATED VOLTAGE as specified on nameplates (tolerance +/- 5%).

19. NEVER USE A COMPRESSOR WHICH IS DEFECTIVE OR OPERATING; ABNORMALLY if the compressor appears to be operating unusually, making strange noises or otherwise appears defective, stop using it immediately and arrange for its repair by an authorised service centre.

20. USE ONLY GENUINE REPLACEMENT PARTS; non-original replacement parts may void your warranty and can lead to malfunction and result in injuries. Do not modify the compressor. Always contact an authorised service centre for any repairs.

21. TURN THE MAIN SWITCH OFF WHEN THE COMPRESSOR IS NOT IN USE; turn the main switch OFF (pos. «0») and unplug the compressor from the mains.

22. DO NOT TOUCH HOT PARTS OF THE COMPRESSOR

23. DO NOT STOP THE COMPRESSOR BY PULLING OUT THE PLUG;

24. USE ONLY RECOMMENDED AIR HANDLING PARTS ACCEPTABLE FOR PRESSURE OF NOT LESS THAN 125 PSI (8.6 BAR).

SAFETY

EXTENSION CABLE

Use only three-way extension cables that have three-pin connecting plugs and three-pole sockets that accept the compressor plug. Do not use extension cables that are damaged or squashed. An under rated cable will cause a drop in line voltage resulting in loss of power and overheating. The table shows the correct size to use depending on the length according to the following parameters (size in [mm²] for a cable with maximum length of 20 mt.):

220/230 V	110/120 V
1,5 mm ²	2,5 mm ²

INSTALLATION

Fit the suction cups underneath the base of the unit as indicated. Position the compressor on a flat surface or one with a max. inclination of 10° in a well-ventilated area. If the surface is sloping and smooth, make sure that the compressor does not move while in operation. If the compressor operates on a shelf or the edge of a stand, ensure that it may not fall off by securing it appropriately.

STARTING (with pressure regulator)

Make sure the main ON/OFF switch is turned OFF (pos. «0»). Plug the compressor into the mains and turn the main switch ON (pos. «I»). Connect the rubber hose or the spiral pipe in the dedicated pipe fitting. The compressor works completely automatically and is controlled by the pressure switch that stops it when air is not requested and starts it again when air is needed.

STARTING (without pressure regulator)

Make sure the main ON/OFF switch is turned OFF (pos. «0»). Plug the compressor into the mains and turn the main switch ON (pos. «I»). Connect the rubber hose or the spiral pipe in the dedicated pipe fitting. This type of compressor without tank is equipped with a device that automatically controls the maximum working pressure even when the user is not using compressed air. The compressor automatically releases any excess air through an appropriate valve. The compressor does not stop automatically. Turn the main O/I switch OFF to switch the compressor off.

ADJUSTING THE WORKING PRESSURE

It is not always necessary to use all the working pressure available, on the contrary, most of the time the pneumatic tool needs less pressure. Set the pressure at the required value by turning the knob clockwise to increase it and anti-clockwise to decrease it.

MAINTENANCE

Make sure that the power supply cable is unplugged from the mains before starting any maintenance jobs on the compressor.

HOW TO RECTIFY SLIGHT ANOMALIES

Air leaks

These may depend on the poor seal of some of the pipe fittings within the machine; check all the pipe fittings by wetting them with soapy water.

The compressor fails to start

If the compressor fails to start, check:

- if all the wires are connected properly
- if the compressor is electrically powered (plugged in correctly, circuit breaker tripped, blown fuses)

The compressor fails to stop (only version with pressure regulator)

If the compressor fails to stop when the maximum pressure is reached, the safety valve of the tank will trip. If this should occur, contact your local authorised service centre to have it repaired.

ATTENTION!

- Ambient temperature to ensure correct operating efficiency: 0°C +25°C (MAX 45°C).
- When the compressor is not in use, turn the main switch OFF (pos. «0»).
- Be very careful when using the compressor, as some of its parts such as the head and delivery pipes can get extremely hot. Do not touch these parts to avoid getting scalded.
- Use the dedicated handles or grips to lift the compressor to move it around.
- If you use the compressor for painting:
 - a) Do not use it indoors or near naked flames.
 - b) Make sure that the area in which you work has a sufficient change of air.
 - c) Protect your nose and mouth by wearing a dedicated
- When you have finished using the compressor always remember to switch it OFF and unplug it from the mains.

TECHNICAL DATA

Maximum running pressure: 8.9 bar

Maximum working pressure: 8 bar

HP / W	RPM	DB(A)
1/800 – 1100 PEAK	3000	71.8

The sound pressure level measured in a free range at a distance of 4 mt. at the maximum working pressure. The value of the sound level may increase from 1 to 10 dB(A) depending on the environment in which the compressor is installed.

HINTS FOR EFFICIENT OPERATION. This compressor has been designed for DIY use with intermittent (not continuous) operation. The use of the compressor for more than 20 min. during one hour is not recommended.

PNEUMATIC CONNECTIONS

Make sure that pneumatic tools for compressed air with maximum pressure characteristics that are adequate for the compressor are used. Do not attempt to repair faulty tubes.

NOTE: SPECIFICATIONS ARE SUBJECT TO CHANGE WITHOUT ANY PRIOR WARNING WHERE NECESSARY.

PROTECTING THE ENVIRONMENT



Separate collection. This product must not be disposed of with normal household waste.

Should you find one day that your Black & Decker product needs replacement, or if it is of no further use to you, do not dispose of it with household waste.

Make this product available for separate collection.



Separate collection of used products and packaging allows materials to be recycled and used again. Re-use of recycled materials helps prevent environmental pollution and reduces the demand for raw materials.

Local regulations may provide for separate collection of electrical products from the household, at municipal waste sites or by the retailer when you purchase a new product. Black & Decker provides a facility for the collection and recycling of Black & Decker products once they have reached the end of their working life. To take advantage of this service please return your product to any authorised repair agent who will collect them on our behalf. You can check the location of your nearest authorized repair agent by contacting your local Black & Decker office at the address indicated in the manual.

GUARANTEE

Black & Decker is confident of the quality of its products and offers an outstanding guarantee. This guarantee statement is in addition to and in no way prejudices your statutory rights. The guarantee is valid within the territories of the Member States of the European Union and the European Free Trade Area. If a Black & Decker product becomes defective due to faulty materials, workmanship or lack of conformity, within 24 months from the date of purchase, Black & Decker guarantees to replace defective parts, repair products subjected to fair wear and tear or replace such products to ensure minimum inconvenience to the customer unless:

- The product has been used for trade, professional or hire purposes;
- The product has been subjected to misuse or neglect;
- The product has sustained damage through foreign objects, substances or accidents;
- Repairs have been attempted by persons other than authorised repair agents or Black & Decker service staff.

Cod. 7.34.835.0000 – 07/06